

Pentax DSI-300 Series Frequency Inverter

USER'S MANUAL



Foreword

Thank you for using the DSI-300 series of high-performance vector control inverter.

New DSI-300 series is a general current vector control inverter integrated with the performance and features in a high degree.

DSI-300 with industry-leading drive performance and functionality control, using unique current vector control algorithm can efficiently drive induction motor to achieve high accuracy, high torque and high-performance control.

Customer success, Market Service! DSI-300 in terms of performance and control are worthy of trust!

This guide explains how to properly use DSI-300 series inverter. Before using (installation, operation, maintenance, inspection, etc.), be sure to carefully read the instructions. Understanding of product safety precautions before using this product.

General notes
<ul style="list-style-type: none">● This manual due to product improvement, specifications change, as well as to the instructions of their ease of use will be appropriate changes. We will update the information number of instructions, issued a revised edition.● This icon in the instructions with the products you ordered may be different, please refer to the specific documentation for products supplied.

Content

Chapter 1 Product information	01
1.1 Safety information and notices.....	01
1.2 Model specification	01
1.3 DSI-300 Series converter series	02
1.4 Product Outline, Mounting Dimension	02
Chapter 2 Electric installations	04
2.1 Main electric circuit terminals.....	04
Chapters Keyboard Operation	08
3.1 Keyboard Operation and display interface	08
Chapter 4 Function parameterstable	11
4.1 Standard Parameters.....	11
Chapters Failure diagnose and policies	67
5.1 Failure alarm and policies.....	67
5.2 Common hilure and treatment method	75

Chapter 1 Product information

1.1 Safety information and notices

In this manual, safety issues the following two categories:



Warning: Due to the dangers posed against the required operation, may result in serious injury and even death;



Caution: Due to the dangers posed against the required operation, may lead to moderate harm or minor injuries, and damage to the equipment;

Installation, commissioning and maintenance of the system, please carefully read this chapter (safety precautions), follow the required safety precautions to operate. DSI-300 is not responsible in case of any injuries and losses caused as a result of improper operations.

1.2 Model specification

DSI-300-1K5G3

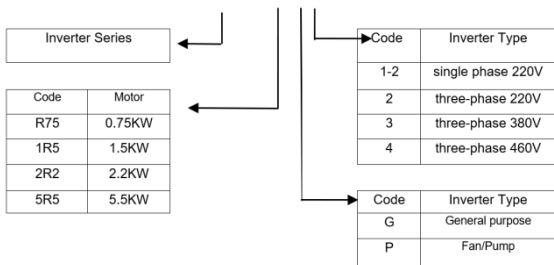

1.3 DSI-300 Series converter series

Frequency converter model	Rated power (KW)	Rated output current (A)	Adapted motor	
			kW	HP
Single phase power supply: 220V, 50Hz/60Hz				
DSI-300-0K7G1	0.75	4.0	0.75	1
DSI-300-1K5G1	1.5	7.0	1.5	2
DSI-300-2K2G1	2.2	9.6	2.2	3
DSI-300-004G1	4	31.0	4	5.5
Three phase power supply: 380V, 50Hz/60Hz				
DSI-300-0K7G3	0.75	2.1	0.75	1
DSI-300-1K5G3	1.5	3.8	1.5	2
DSI-300-2K2G3	2.2	5.1	2.2	3
DSI-300-004G3	4	9	4	5.5
DSI-300-5K5G3	5.5	13	5.5	7.5
DSI-300-7K5G3	7.5	17	7.5	10
DSI-300-011G3	11.0	25	11	15
DSI-300-015G3	15.0	32	15	20
DSI-300-018G3	18.5	37	18	25
DSI-300-022G3	22.0	45	22.0	30
DSI-300-030G3	30.0	60	30.0	40
DSI-300-037G3	37.0	75	37.0	50

Table 1-1 DSI-300 Series

1.4 Product Outline, Mounting Dimension

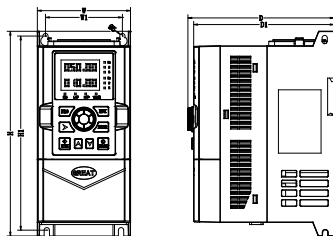

Model Type	Outsize(mm)			Outsize(mm)			Mounting hole(d)
	W	H	D	W1	H1	D1	
DSI-300-0K4G1	89.6	197.2	139	74	187	135	Φ5
DSI-300-0K7G1							
DSI-300-1K5G1							
DSI-300-2K2G1							
DSI-300-0K7G3							
DSI-300-1K5G3							
DSI-300-2K2G3	102	202	162	90	190	158	Φ5.6
DSI-300-004G3							
DSI-300-5K5G3							
DSI-300-004G1	125	242.5	169.5	108.5	227	166	Φ6.4
DSI-300-7K5G3							
DSI-300-011G3							
DSI-300-015G3	165	297	206.2	147	278.5	202	Φ7
DSI-300-018G3							
DSI-300-022G3							
DSI-300-030G3	225	360	238	206	342	232	Φ7
DSI-300-037G3							

1.4.1 Keyboard specification

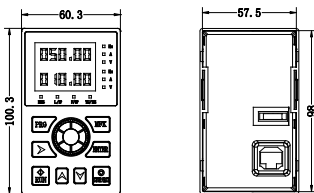

Keyboard direct opening size: 57.5mm*98mm

1.4.2 Keyboard warehouse dimension

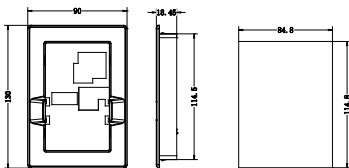

Keyboard warehouse opening size: 84.8mm*114.8mm

Chapter 2 Electric installations

2.1 Main circuit terminals

1) DSI-300 main circuit terminals:

Terminal marks	Description/Display	Instruction
R.S.T/L.N	Power supply input terminals	Connection point of three-phase 380V /single-phase 220V AC power
P+.PB	External Break resistor reserved	Connect Break resistor resistance
U.V.W	Frequency converter output terminals	Connect three phase motor
	Earth terminal	Earth terminal

2.1.2 DSI-300 diagram

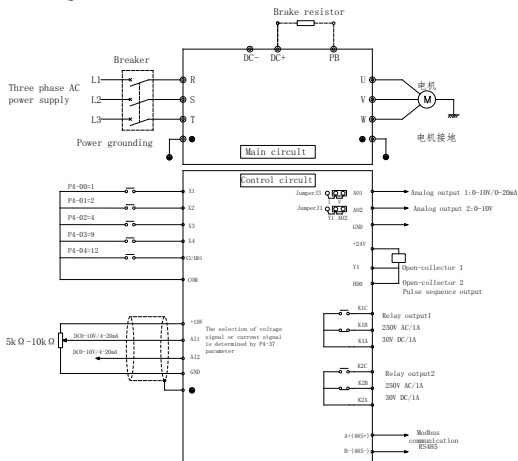

Fig 2-2 DSI-300 diagram

2.1.3 Control circuit terminal arrangement

The control circuit terminals:

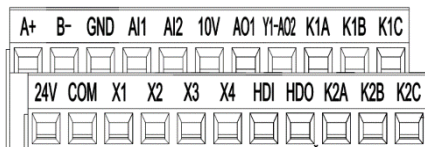

Fig 2-4 DSI-300 (isolated version) control circuit terminals

Note: The control circuit terminals have optical coupling isolation, NPN and PNP input chosen by jumper J4 on control board.

2.1.4 Terminals function description :

Category	Terminal symbol	Terminal Description/ Display	Function instruction
Power supply	10V-GND	External terminal of 10V power supply	Provide +10V power supply for external units, with maximum output current of 150mA. It is generally used as the operating power supply for the external potentiometer. The potentiometer resistance range
	24V-COM	External terminal of 24V power supply	Provide +24V power supply for external units. It is generally used as the operating power supply for digital input/output terminal and the external sensor. Maximum output current : 200mA
Analog inputs	AI1-GND	Analog input terminal 1	1. Input range: DC 0V to 10V / 0- 20mA. Code P4-37 as constraints. 2. Input impedance : 22k Ω of voltage input, 500 Ω of current input.
	AI2-GND	Analog input terminal 2	1. Input range: DC 0V to 10V / 0- 20mA. Code P4-37 as constraints. 2. Input impedance : 22k Ω of voltage input, 500 Ω of current input.
Analog outputs	AO1-GND	Analog output terminal 1	Output voltage range: 0V-10V Output current range: 0 to 20mA, 4to20mA (Code P5-23) Chosen by jumper J3 on control board.
	AO2-GND	Analog output terminal 2	Output voltage range: 0V-10V (chosen by jumper J1 to AO2 on control board)

Digital inputs	X1-COM	Digital input 1	HDI can be used as high-speed pulse input channel except XI-X4. Maximum input frequency: 100kHz. The highest input frequency: 50kHz Input impedance: 1kΩ. Electrical level input range: 5V-30V.
	X2-COM	Digital input 2	
	X3-COM	Digital input 3	
	X4-COM	Digital input 4	
	HDI-COM	Digital input 5	
	A+ B-	Communication	MODBUS RS485 port, non-isolation.
Digital outputs	Y1-COM	Open collector output	Open collector output. Chosen by jumper J1 to Y1 on control board)
	HDO-COM	High-speed pulse output	High-speed pulse output, maximum frequency can reach 50kHz. Code P5.00 as constraints. As open collector output, the function is same as Y1.
	K1A-K1B-K1C	Relay output 1	A:common point B:normally closed C:normally open Contact driving capacity:AC250V, 3A, COS ϕ =0.4, DC30V.1A
	K2A-K2B-K2C	Relay output 2	

2.1.5 Analog input terminal

Because the weak analog signal will be easily affected by the external interference, generally shielded cable shall be used, the cable length shall be as short as possible and no longer than 20 meters. In case the analog signal is subject to severe interference, analog signal source side shall be installed with filter capacitor or ferrite magnetic ring.

Chapters Keyboard Operation

3.1 Display Interface

Modification of function parameter, monitoring of inverter operation, control of inverter operation (start and stop) can be performed through the operation panel. Its shape and function area are shown as below :

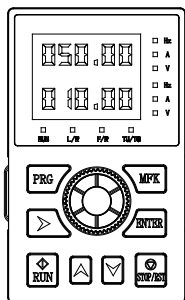

Fig 3-1 Diagram of operation panel

1) Function description light:

- ◇ RUN: Running indicator, *ON: running state, *OFF: stop state.
- ◇ L/R: Command source indicator keyboard operation, terminal operation and remote operation (communication control) indicator.
 - *ON: terminal operation control state
 - *OFF: keyboard operation control state
 - *Flashing: remote operation control state
- ◇ F/R: Forward/Reserved Running Light
 - *ON: forward running
 - *OFF: Reserved running
- ◇ TU/TC: Tuning/Fault indicator
 - *ON: torque control mode
 - *Slow flashing: tuning state
 - *Quick flashing: fault state

2) Unit indicator light:

Hz	Frequency unit
A	Current unit
V	Voltage unit
RPM (Hz+A)	Revolving speed unit
%(A+V)	Percentage

3) Date display area:

2 rows of 5-bit LED display, can display setting frequency, output frequency, various monitoring data and alarm code.

4)Function description of operation panel

Keyboard Parameter	Function	Description
PRG	Programming key	Primary menu enter or exit.
ENTER	Confirmation key	Gradually step into the menu screen, set parameters confirmation.
▲	Increase key	Increase of the data or Code.
▼	Decrease key	Decrease of the data or Code.
▶	Shift key	On the stop display interface or running display interface, it can be used to circularly select the display parameters. When modifying the parameters, it can be used to select the bits of parameter for modification
RUN	Running key	It is used to start the running of the inverter under keyboard control mode.
STOP/RESET	Stop/reset	In running status, it can stop the running by pressing this key. In alarm status, it can reset operation with this key. The characteristics of this key are limited by Code P7.02.
MFK	Multi-function selection key	It is used as functions witching selection according to P7-01.

Table 3-1Function description of operation panel

Chapter4 Parameter Function Table

4.1 Standard Parameters are explained as follows :

“★” : indicates that the parameter setup value cannot be modified when the inverter is in the running status.

“●” : indicates that the parameter value is the actual detection record and cannot be modified.

“☆” : indicates that the parameter setup value can be modified when the inverter is in stop status and running status.

“-” : indicates that the parameter factory value is relevant to power or model, for specifications please refer to corresponding parameter description.

Group P0: Standard Parameters

Code	Description /Display	Setting Range	Factory Setting	Property	Command address
P0-01	Motor control mode	0: SVC control 2: V/F control	2	★	61441
P0-02	Command source selection	0: Operating panel (keypad & display) (indicator 'LOCAL/REMOT' turns OFF) 1: Terminal I/O control (indicator 'LOCAL/REMOT' turns ON) 2: Serial comms. (indicator 'LOCAL/REMOT' turns flashing)	0	☆	61442

Code	Description/Display	Setting Range	Factory Setting	Property	Command address
P0-03	Main frequency source X selection	0: Digital setting P0-08 (pressing UP/DOWN can revise F0-08 easily, and the revised value won't be cleared even after power off) 1: Digital setting P0-08 (pressing UP/DOWN can change F0-08 easily, but the revised value would be cleared after power off) 2: AI1 3: AI2 4: Potentiometer 5: Pulse setting (HDI) 6: Multi-reference setting 7: Simple PLC 8: PID 9: Communication setting	4	★	61443
P0-04	Auxiliary frequency source Y selection	Same to P0-03 (Main frequency source X selection)	0	★	61444

Code	Description/Display	Setting Range	Factory Setting	Property	Command address
P0-05	Auxiliary frequency source Y range selection	0: Relative to maximum frequency 1: Relative to frequency source X	0	☆	61445
P0-06	Auxiliary frequency source Y range	0% to 150%	100%	☆	61446
P0-07	Final frequency reference setting selection	Units position: Frequency reference selection 0: Main frequency reference 1: Main and auxiliary calculation (based on tens position) 2: Switchover between main and auxiliary 3: Switchover between main and "main & auxiliary calculation" 4: Switchover between auxiliary and "main & auxiliary calculation" Tens position: main and auxiliary calculation formula 0: Main + auxiliary 1: Main - auxiliary 2: Max. (main, auxiliary) 3: Min. (main, auxiliary)	00	☆	61447

Code	Description / Display	Setting Range	Factory Setting	Property	Command address
P0-08	Preset frequency	0.00Hz to P0-10	50.00Hz	☆	61448
P0-09	Running direction	0: Run in the default direction (FWD/REV indicator off) 1: Run in the direction reverse to the default direction (FWD/REV indicator on)	0	☆	61449
P0-10	Max. frequency	50.00Hz to 320.00Hz (P0-22=2) 50.0Hz to 3200.0Hz (P0-22=l)	50.00Hz 50.0Hz	★	61450
P0-11	Setting channel of frequency reference upper limit	0: Set by P0-12 1: All 2: AI2 3: Potentiometer 4: Pulse reference (HDI) 5: Communication reference	0	★	61451
P0-12	Frequency reference upper limit	Frequency reference lower limit (P0-14) to maximum frequency (P0-10)	50.00Hz	☆	61452
P0-13	Frequency reference upper limit offset	0.00Hz to max. frequency (F0-10)	0.00Hz	☆	61453
P0-14	Frequency reference lower limit	0.00Hz to frequency upper limit (P0-12)	0.00Hz	☆	61454
P0-15	Carrier frequency	0.5KHz to 16.0KHz	Model dependent	☆	61455
P0-16	Carrier frequency adjusting with temperature	0: Disabled 1: Enabled	1	☆	61456

Code	Description/ Display	Setting Range	Factory Setting	Property	Command address
P0-17	Acceleration time 1	0.00s to 650.00s (P0-19 = 2)	Model dependent	☆	61457
P0-18	Deceleration time 1	0.0s to 6500.0s (P0-19 = 1) 0s to 65000s (P0-19 = 0)			61458
P0-19	Acc./Dec. time unit	0: 1s 1: 0.1s 2: 0.01s	1	★	61459
P0-21	Auxiliary frequency source offset frequency	0.00Hz to Max. Frequency (P0-10)	0.00Hz	☆	61461
P0-22	Frequency reference resolution	1: 0.1Hz 2: 0.01Hz	2	★	61462
P0-23	Retentive of digital setting frequency upon stop	0: Not retentive 1: Retentive	0	☆	61463
P0-24	Remain	-	1	☆	61464
P0-25	Acc./Dec. time base frequency	0: Max. frequency (P0- 10) 1: Frequency reference	0	★	61465

Code	Description/ Display	Setting Range	Factory Setting	Property	Command address
P0-26	Base frequency for UP/DOWN modification during running	0: Running frequency 1: Frequency reference	0	★	61466
P0-27	Command source + frequency source	Units position: operating panel (keypad & display) + frequency reference setting channel 0: No function 1: Digital setting 2: AI1 3: AI2 4: Potentiometer 5: Pulse reference (HDI) 6: Multi-reference 7: Simple PLC 8: PID reference 9: Serial comms. Tens: terminal I/O control + frequency reference setting channel Hundreds: serial comms. + frequency reference setting channel Thousands: Auto command frequency source selection	0000	☆	61467

Group P1: Motor 1 Parameters

Code	Description /Display	Setting Range	Factory Setting	Property	Command address
P1-00	Motor type selection	0: Common asynchronous motor 1: Variable frequency asynchronous motor	0	★	61696
P1-01	Rated motor power	0.1 to 1000.0kW	Model dependent	★	61697
P1-02	Rated motor voltage	1 to 2000V	Model dependent	★	61698
P1-03	Rated motor current	0.01 to 100.00A	Model dependent	★	61699
P1-04	Rated motor frequency	0.01 To max. frequency	Model dependent	★	61700
P1-05	Rated motor speed	1 to 65535rpm	Model dependent	★	61701
P1-10	No-load current	0.01 to P1-03	Model dependent	★	61706
P1-37	Motor auto-tuning method selection	0: No auto-tuning 1: Static auto-tuning 1 2: Dynamic auto-tuning 3: Static auto-tuning 2	0	★	61733

Group P2: Vector Control Parameters

Code	Description /Display	Setting Range	Factory Setting	Property	Command address
P2-00	Speed loop proportional gain1	1 to 100	30	☆	61952
P2-01	Speed loop integral Time 1	0.01 to 10.00s	0.50s	☆	61953
P2-02	Switchover frequency 1	0.00 to P2-05	5.00Hz	☆	61954
P2-03	Speed loop proportional gain 2	1 to 100	20	☆	61955

P2 group function codes are valid for vector control and invalid for V/F control

Code	Description /Display	Setting Range	Factory Setting	Property	Command address
P2-04	Speed loop integral time 2	0.01 to 10.00s	1.00s	☆	61956
P2-05	Switchover frequency 2	P2.02 to max. frequency	10.00Hz	☆	61957
P2-06	SVC/FVC slip compensation gain	50% to 200%	150%	☆	61958
P2-07	Speed feedback filter time constant	0.000 to 0.100s	0.000s	☆	61959
P2-08	Reverse	-	64	☆	61960

Code	Description /Display	Setting Range	Factory Setting	Property	Command address
P2-09	Torque limit source in speed control	0: P2-10 1: AI1 2: AI2 3: Potentiometer 4: Pulse reference (HDI) 5: Serial comms. 6: Min. (AI1, AI2) 7: Max. (AI1, AI2) The torque limit is defined by F2-10.	0	☆	61961
P2-10	Digital setting of torque limit in speed control	0.0 to 200.0%	150.0%	☆	61692
P2-13	Excitation adjustment proportional gain	0 to 60000	2000	☆	61965
P2-14	Excitation adjustment integral gain	0 to 60000	1300	☆	61966

Code	Description /Display	Setting Range	Factory Setting	Property	Command address
P2-15	Torque adjustment proportional gain	0 to 60000	2000	☆	61967
P2-16	Torque adjustment integral gain	0 to 60000	1300	☆	61968
P2-17	Speed loop integral separation selection	One position: Integral separate 0: Disable 1: Enable	0	☆	61969

Group F3: V/F Control Parameters

Code	Description /Display	Setting Range	Factory Setting	Property	Command address
P3-00	V/F curve setting	0, 2-9: Linear V/F 11: Multi-point V/F 10: V/F separation 11: Specific V/F separation	0	★	62208
P3-01	Torque boost	0.0%: automatic torque boost 0.1 to 30%	Model dependent	☆	62209
P3-02	Cut-off frequency of torque boost	0.00Hz to max. frequency	50.00Hz	★	62210
P3-03	Multi-point V/F frequency 1	0.00Hz to P3-05	0.00Hz	★	62211
P3-04	Multi-point V/F voltage 1	0.0 to 100.0%	0%	★	62212
P3-05	Multi-point V/F frequency 2	P3-03 to P3-07	0.00Hz	★	62213
P3-06	Multi-point V/F voltage 2	0.0 to 100.0%	0%	★	62214
P3-07	Multi-point V/F frequency 3	F3-05 to rated motor frequency (P1-04)	0.00 Hz	★	62215

Code	Description /Display	Setting Range	Factory Setting	Property	Command address
P3-08	Multi-point V/F voltage 3	0.0% to 100.0%	100.0%	★	62216
P3-09	V/F slip compensation gain	0.0 to 200.0%	0.0%	☆	62217
P3-10	V/F over-excitation gain	0 to 200	64	☆	62218
P3-11	V/F oscillation suppression gain	0 to 100	Model dependent	☆	62219

P4 group-input terminal

Code	Description/Display	Setting Range	Factory Setting	Property	Command address
P4-00	X1 function selection	0: no function 1: Forward run (FWD) 2: Reverser run (REV) 3: Three-wire control 4: Forward jog (FJOG) 5: Reverse jog (RJOG) 6: Terminal UP 7: Terminal DOWN	1	★	62464
P4-01	X2 function selection	8: Coast to stop 9: Fault reset (RESET) 10: RUN disabled 11: External fault NO input 12: Multi-reference terminal 1 13: Multi-reference terminal 2 14: Multi-reference terminal 3 15: Multi-reference terminal 4 16: Terminal 1 for acc./dec. Time selection	2	★	62465
P4-02	X3 function selection	17: Terminal 2 for acc./dec. Time selection 18: Frequency reference setting channel switchover 19: UP and DOWN setting clear (terminal, operation panel) 20: Command source switchover 1	4	★	62466
P4-03	X4 function selection	21: Acc./Dec. prohibited 22: PID disabled 23: PLC state reset 24: Wobble disabled 25: Counter input 26: Counter reset 27: Length signal pulses count 28: Length reset 29: Torque control prohibited	9	★	62467

Code	Description / Display	Setting Range	Factory Setting	Property	Command address
P4-03	X4 function selection	30: Pulse input as frequency reference (valid only for HDI) 31: Reserved 32: Immediate DC injection braking 33: External fault NC input 34: Frequency modification enable 35: PID operation direction reverse 36: External stop 1 37: Command source switchover 2	9	★	62467
P4-04	HDI (HDI) function selection	38: PID integral disabled 39: Switchover between main frequency reference and preset frequency 40: Switchover between auxiliary frequency reference and preset frequency 43: PID parameter switchover 44: User-defined fault 1 45: User-defined fault 2 46: Speed control/ Torque control 47: Emergency stop 48: External stop 2 49: Deceleration DC injection braking 50: Clear running time this time	12	★	62468
P4-10	Terminal X filter time	0.000 to 1.000s	0.010s	☆	62474

P4-11	Terminal I/O control mode	0: Two-wire control mode 1 1: Two-wire control mode 2 2: Three-wire control mode 1 3: Three-wire control mode 2	0	★	62475
-------	---------------------------------	--	---	---	-------

Code	Description /Display	Setting Range	Factory Setting	Property	Command address
P4-12	Terminal UP/DOWN rate	0.001 to 65.535Hz/s	1.00Hz/s	☆	62476
P4-13	AI curve 1 min. input	0.00V to P4-15	0.00v	☆	62477
P4-14	Corresponding percentage of AI curve 1 min. input	-100.0% to 100.0%	0.0%	☆	62478
P4-15	AI curve 1 max. input	P4-13 to 10.00V	10.00V	☆	62479
P4-16	Corresponding percentage of AI curve 1 max. input	-100.0% to 100.0%	100.0%	☆	62480
P4-17	AI1 filter time	0.00 to 10.00s	0.10s	☆	62481
P4-18	AI curve 2 min. input	0.00V to P4-20	0.00v	☆	62482

Code	Description /Display	Setting Range	Factory Setting	Property	Command address
P4-19	Corresponding percentage of AI curve 2 min. input	-100.0% to 100.0%	0.0%	☆	62483
P4-20	AI curve 2 max. input	P4-18 to 10.00V	10.00V	☆	62484
P4-21	Corresponding percentage of AI curve 2 max. input	-100.0% to 100.0%	100.0%	☆	62485
P4-22	AI2 filter time	0.00 to 10.00s	0.10s	☆	62486
P4-23	AI curve 3 min. input	0.00V to P4-25	0.00V	☆	62482
P4-24	Corresponding percentage of AI curve 3 min. input	-100.0% to 100.0%	0.0%	☆	62483

Code	Description /Display	Setting Range	Factory Setting	Property	Command address
P4-25	AI curve 3 max. input	P4-23 to 10.00V	10.00V	☆	62484
P4-26	Corresponding percentage of AI curve 3 max. input	-100.0% to 100.0%	100.0%	☆	62485
P4-27	AI3 filter time	0.00 to 10.00s	0.10s	☆	62486
P4-28	Min input of HDI pulse	0.00kHz to P4-30	0.00kHz	☆	62492
P4-29	Corresponding percentage of pulse min. input	-100.0% to 100.0%	0.0%	☆	62493
P4-30	Pulse max. input	P4-28 to 50.00kHz	50.00 kHz	☆	62494

Code	Description /Display	Setting Range	Factory Setting	Property	Command address
P4-31	Corresponding percentage of pulse max. (HDI) input	-100.0% to 100.0%	100.0%	☆	62495
P4-32	Pulse filter time	0.00 to 10.00s	0.10s	☆	62496
P4-33	AI curve selection	Units position: AI1 curve selection 1: Curve 1 (2 points, see P4-13 to P4-16) 2: Curve 2 (2 points, see P4-18 to P4-21) 3: Curve 3 (2 points, see P4-23 to P4-26) Tens position: AI2 curve Hundreds position: AI3 curve	321	☆	62497

P4-34	Setting selection when AI less than min. input	Units position: AI1 0: Corresponding percentage of min. input 1: 0.0% Tens position: AI2 Hundreds position: AI3	000	☆	62498
-------	--	---	-----	---	-------

Code	Description /Display	Setting Range	Factory Setting	Property	Command address
P4-35	Terminal X active mode selection 1	0: High level active 1: Low level active Units position: X1 active mode Tens: X2 active mode Hundreds: X3 active mode Thousands: X4 active mode Ten thousands: HDI active mode	000	☆	62499
P4-37	All input voltage/current selection	Units position: AI1 Tens position: AI2 0: Voltage input 1: Current input	10	★	62501
P4-38	X1 switch-on delay	0.0 to 6553.5s	0.0s	★	62502
P4-39	X2 switch-on delay	0.0 to 6553.5s	0.0s	★	62503
P4-40	X3 switch-on delay	0.0 to 6553.5s	0.0s	★	62504
P4-41	X4 switch-on delay	0.0 to 6553.5s	0.0s	★	62505
P4-42	HDI switch-on delay	0.0 to 6553.5s	0.0s	★	62506
P4-48	X1 switch-off delay	0.0 to 6553.5s	0.0s	★	62512
P4-49	X2 switch-off delay	0.0 to 6553.5s	0.0s	★	62513
P4-50	X3 switch-off delay	0.0 to 6553.5s	0.0s	★	62514
P4-51	X4 switch-off delay	0.0 to 6553.5s	0.0s	★	62515
P4-52	HDI switch-off delay	0.0 to 6553.5s	0.0s	★	62516

Group P5: Output Terminals

Code	Description /Display	Setting Range	Factory Setting	Property	Command address
P5-00	HDO terminal output mode	0: Pulse output (HDO) 1: Digital output (FMR)	0	☆	62720
P5-01	HDO function selection (FMR)	0: No output 1: AC drive running 2: Fault output 3: Frequency level detection 4: Frequency reached 5: Zero-speed running (no output at stop) 6: Motor overload pending	0	☆	62721
P5-02	Relay RY1 function selection (K1A-K1B-K1C)	7: AC drive overload pending 8: Set count value Reached 9: Designated count value reached 10: Length reached 11: PLC circle completed 12: Accumulative running time reached	2	☆	62722
P5-03	Relay RY1 function selection (K2A-K2B-K2C)	13: Frequency limited 14: Torque limited 15: Ready for RUN 16: AI1>AI2 17: Frequency upper limit reached 18: Frequency lower limit reached (no output at stop)	0	☆	62723

Code	Description/Display	Setting Range	Factory Setting	Property	Command address
P5-03	Relay RY1 function selection (K2A-K2B-K2C)	19: Under voltage 20: Communication setting 23: Zero-speed running 2 (having output at stop) 24: Accumulative power-on time reached 25: Frequency level detection 2 26: Frequency 1 reached 27: Frequency 2 reached 28: Current 1 reached 29: Current 2 reached 30: Timing reached 31: All input exceeding limit	0	☆	62723
P5-04	Y1 function selection	32: Load lost 33: Reverse running 34: Zero current 35: IGBT temperature reached 36: Output current exceeding limit 37: Frequency lower limit reached (having output at stop) 38: Alarm output (keep running) 40: Current running time reached 41: Fault output	1	☆	62724

Code	Description /Display	Setting Range	Factory Setting	Property	Command address
P5-06	HDO function selection	0: Running frequency 1: Frequency reference 2: Output current 3: Output torque (absolute value) 4: Output power 5: Output voltage 6: Pulse input (100% Correspond 100.0kHz) 7: All 8: AI2	0	☆	62726
P5-07	AO1 function selection	9: Potentiometer 10: Length 11: Counting value 12: Communication reference 13: Motor speed	0	☆	62727
P5-08	AO2 function selection	14: Output current (100.0% Correspond 1000.0A) 15: Output voltage (100.0% corresponding 1000.0V) 16: Reserved 17: Output torque of the AC drive	0	☆	62728
P5-09	Max. HDO output frequency	0.01 to 50.00kHz	50.00 kHz	☆	62729
P5-10	AO1 zero offset coefficient	-100.0% to 100.0%	0.0%	☆	62730
P5-11	AO1 gain	-10.00 to 10.00	1.00	☆	62731
P5-17	FMR switch-on delay	0.0 to 6553.5s	0.0s	☆	62737

Code	Description /Display	Setting Range	Factory Setting	Property	Command address
P5-18	RY1 switch-on delay	0.0 to 6553.5s	0.0s	☆	62738
P5-19	RY2 switch-on delay	0.0 to 6553.5s	0.0s	☆	62739
P5-20	Y1 switch-on delay	0.0 to 6553.5s	0.0s	☆	62740
P5-21	Reserved	-	-	-	62741
P5-22	Y active mode selection	0: Positive logic active 1: Negative logic active Units: HDO active mode Tens: RY1 Hundreds: RY2 Thousands: Y1 Ten thousands: reserved	00000	☆	62742
P5-23	AO current output selection	Units: AO1 Tens: AO2 0: 0~20 mA 1: 4~20mA	0	☆	62743
P5-24	FMR switch-off delay	0.0 to 6553.5s	0.0s	☆	62744
P5-25	RY1 switch-off delay	0.0 to 6553.5s	0.0s	☆	62745
P5-26	RY2 switch-off delay	0.0 to 6553.5s	0.0s	☆	62746
P5-27	Y1 switch-off delay	0.0 to 6553.5s	0.0s	☆	62747

Group P6: Start/Stop Control

Code	Description /Display	Setting Range	Factory Setting	Property	Command address
P6-00	Start mode	0: Direct start 1: Catching a spinning motor 2: Pre-excited start	0	☆	62976
P6-01	Mode of catching a spinning motor	0: From stop frequency 1: From 50 Hz 2: From max. frequency	0	★	62977
P6-02	Speed of catching a spinning motor	1 to 100	20	☆	62978
P6-03	Start frequency	0Hz to P0-08	0.00Hz	☆	62979
P6-04	Start frequency holding time	0.0 to 100.0s	0.0s	★	62980
P6-05	DC injection braking 1 level/Pre excitation level	0% to 100%	0%	★	62981
P6-06	DC injection braking 1 active time /Pre-excitation active time	0.0 to 100.0s	0.0s	★	62982

Code	Description /Display	Setting Range	Factory Setting	Property	Command address
P6-07	Acceleration/Deceleration mode	0: Linear acc./dec. 1: Static S-curve acc./ dec. 2: Dynamic S-curve acc./ dec.	0	★	62983
P6-08	Acceleration/Deceleration mode	0.0% to (100.0% - P6-09)	30.0%	★	62984
P6-09	Acceleration/Deceleration mode	0.0% to (100.0% - P6-08)	30.0%	☆	62985
P6-10	Stop mode	0: Decelerate to stop 1: Coast to stop	0	☆	62986
P6-11	DC injection braking 2 start frequency	0.00 Hz to Max. frequency	0.00Hz	☆	62987
P6-12	DC injection braking 2 delay time	0.0 to 100.0s	0.0s	☆	62988
P6-13	DC injection braking 2 level	0% to 100%	0%	☆	62989
P6-14	DC injection braking 2 active time	0.0s to 100.0s	0.0s	☆	62990
P6-15	Braking use ratio	0% to 100%	100%	☆	62991

Group P7: Keypad Operation and LED Display

Code	Description /Display	Setting Range	Factory Setting	Property	Command address
P7-01	MFK key function selection	0: MF.K key disabled 1: Switchover from remote control (terminal or communication) to keypad control 2: Switchover between FWD/REV 3: Forward jog 4: Reverse jog	0	☆	63233
P7-02	STOP/RESET key function	0: STOP/RESET key enabled only in keypad control 1: STOP/RESET key enabled in any operation mode	1	☆	63234
P7-03	LED 1 display running parameters 1	0000 to FFFF Bit00: running frequency 1 (Hz) Bit01: Frequency reference (Hz) Bit02: Bus voltage(V) Bit03: Output voltage (V) Bit04: Output current (A) Bit05: Output power (kW) Bit06: Output torque (%) Bit07: X state Bit08: Y state Bit09: AI1 voltage (V) Bit10: AI2 voltage (V) Bit11: AI3 potentiometer voltage (V) Bit12: Count value Bit13: Reserved Bit14: Load speed display Bit15: PID reference	001F	☆	63235

Code	Description /Display	Setting Range	Factor y Setting	Property	Command address
P7-04	LED 1 display running parameters 2	0000 to FFFF Bit00: PID feedback Bit01: PLC stage Bit02: HDI Pulse reference (kHz) Bit03: Running frequency 2 Bit04: Remaining running time Bit05: AI1 voltage before correction Bit06: AI2 voltage before correction Bit07: AI3 potentiometer voltage before correction Bit08: Motor speed Bit09: Current power-on time (H) Bit10: Current running time (Min) Bit11: HDI Pulse reference (Hz) Bit12: Communication reference Bit13: Encoder feedback speed (Hz) Bit14: Main frequency display (Hz) Bit15: Auxiliary frequency display (Hz)	0000	☆	63236

Code	Description /Display	Setting Range	Factor y Setting	Property	Command address
P7-05	LED 1 display stop parameters	0000 to FFFF Bit00: Frequency reference (Hz) Bit01: Bus voltage(V) Bit02: X state Bit03: Y state Bit04: AI1 voltage (V) Bit05: AI2 voltage (V) Bit06: AI3 potentiometer voltage (V) Bit07: Count value Bit08: Length value Bit09: PLC stage Bit10: Load speed Bit11: PID reference Bit12: HDI Pulse reference (Hz) Bit13: PID feedback	0033	☆	63237
P7-06	Load speed display coefficient	0.0001 to 6.5000	1.0000	☆	63238
P7-07	Heatsink temperature of AC Drive IGBT	0.0°C to 100.0°C	-	●	63239
P7-09	Accumulative running time	0 to 65535h	-	☆	63241
P7-12	Number of decimal places for load speed display	0: 0 bit decimal 1: 1 bit decimal 2: 2 bits decimal 3: 3 bits decimal	1	☆	63244

Code	Description /Display	Setting Range	Factor y Setting	Property	Command address
P7-13	Accumulative power-on time	0 to 65535h	-	●	63245
P7-14	Accumulative power consumption	0 to 65535kWh	-	●	63246
P7-17	LED 2 display stop parameters	00 to 65 (U0-00 to U0-65)	02	☆	63249
P7-18	LED 2 running parameters	00 to 65 (U0-00 to U0-65)	04	☆	63250

Group P8: Auxiliary Functions

Code	Description /Display	Setting Range	Factory Setting	Property	Command address
P8-00	Jog frequency reference	0.00Hz to max. frequency	2.00Hz	☆	63488
P8-01	Jog acceleration time	0.0 to 6500.0s	20.0s	☆	63489
P8-02	Jog deceleration time	0.0 to 6500.0s	20.0s	☆	63490
P8-03	Acceleration time 2	0.0 to 6500.0s	Model dependent	☆	63491
P8-04	Deceleration time 2	0.0 to 6500.0s	Model dependent	☆	63492
P8-05	Acceleration time 3	0.0 to 6500.0s	Model dependent	☆	63493
P8-06	Deceleration time 3	0.0 to 6500.0s	Model dependent	☆	63494
P8-07	Acceleration time 4	0.0 to 6500.0s	Model dependent	☆	63495
P8-08	Deceleration time 4	0.0 to 6500.0s	Model dependent	☆	63496

Code	Description /Display	Setting Range	Factory Setting	Property	Command address
P8-09	Frequency jump 1	0.00Hz to max. frequency	0.00Hz	☆	63497
P8-10	Frequency jump 2	0.00Hz to max. frequency	0.00Hz	☆	63498
P8-14	Running mode when frequency reference lower than frequency lower limit	0: Run at frequency reference lower limit 1: Stop 2: Run at zero speed	0	☆	63502
P8-15	Droop rate	0.00 to 10.00Hz	0.00Hz	☆	63503
P8-16	Accumulative power-on time threshold	0 to 65000h	0h	☆	63504
P8-17	Accumulative running time threshold	0 to 65000h	0h	☆	63505
P8-18	Startup protection selection	0: Disabled 1: Enabled	0	☆	63506
P8-19	Frequency detection value (FDT1)	0.00Hz to max. frequency	50.00Hz	☆	63507
P8-20	Frequency detection hysteresis	0.0% to 100.0% (FDT1 electric level)	5.0%	☆	63508

Code	Description /Display	Setting Range	Factory Setting	Property	Command address
P8-21	Detection width of target frequency reached	0.0% to 100.0% (The max. frequency)	0.0%	☆	63509
P8-25	Switchover frequency of acc. time 1 and acc. time 2	0.00Hz to max. frequency	0.00Hz	☆	63513
P8-26	Switchover frequency of dec. time 1 and dec. time 2	0.00Hz to max. frequency	0.00Hz	☆	63514
P8-27	Set highest priority to terminal JOG function	0: Disabled 1: Enabled	0	☆	63515
P8-28	Frequency detection value (FDT2)	0.00Hz to max. frequency	50.00Hz	☆	63516
P8-29	Frequency detection hysteresis 2	0.0% to 100.0% (FDT2 electric level)	5.0%	☆	63517
P8-30	Detection of frequency 1	0.00Hz to max. frequency	50.00Hz	☆	63518

Code	Description /Display	Setting Range	Factory Setting	Property	Command address
P8-31	Detection width of frequency 1	0.0% to 100.0% (The max. frequency)	0.0%	☆	63519
P8-32	Detection of frequency 2	0.00Hz to The max. frequency	50.00Hz	☆	63520
P8-33	Detection width of frequency 2	0.0% to 100.0% (The max. frequency)	0.0%	☆	63521
P8-34	Zero current detection level	0.0% to 300.0%	5.0%	☆	63522
P8-35	Zero current detection delay	0.01 to 600.00s	0.10s	☆	63523
P8-36	Output overcurrent threshold	0.0% (no detection) 0.1% to 300.0% (rated motor current)	200.0%	☆	63524
P8-37	Output overcurrent detection delay	0.00 to 600.00s	0.00s	☆	63525

P8-38	Detection level of current 1	0.0% to 300.0% (rated motor current)	100.0%	☆	63526
-------	------------------------------	---	--------	---	-------

Code	Description /Display	Setting Range	Factory Setting	Property	Command address
P8-39	Detection width of current 2	0.0% to 300.0% (rated motor current)	0.0%	☆	63527
P8-40	Detection level of current 2	0.0% to 300.0% (rated motor current)	100.0%	☆	63528
P8-41	Detection width of current 2	0.0% to 300.0% (rated motor current)	0.0%	☆	63529
P8-42	Timing function	0: Disabled 1: Enabled	0	★	63530
P8-43	Running time setting channel	0: Set by F8-44 1: AI1 2: AI2 3: Potentiometer (100% of analog input corresponds to the value of P8-44)	0	★	63531
P8-44	Running time	0.0 to 6500.0Min	0.0Min	★	63532
P8-45	AI1 input voltage lower limit	0.00V to P8-46	3.10V	☆	63533

Code	Description /Display	Setting Range	Factory Setting	Property	Command address
P8-46	AI1 input voltage upper limit	P8-45 to 10.00V	6.80V	☆	63534
P8-47	IGBT temperature threshold	0°C to 100°C	75°C	☆	63535
P8-48	Cooling fan working mode	0: Working during drive running 1: Working continuously	0	☆	63536
P8-49	Wake up frequency	Hibernating frequency (P8-51) to max. frequency (P0-10)	0.00Hz	☆	63537
P8-50	Wake up delay time	0.0 to 6500.0s	0.0s	☆	63538
P8-51	Hibernating frequency	0.00Hz to wake up frequency (P8-49)	0.00Hz	☆	63539
P8-52	Hibernating delay time	0.0 to 6500.0s	0.0s	☆	63540
P8-53	Running time threshold this time	0.0 to 6500.0Min	0.0Min	☆	63541

Group P9: Fault and Protection

Code	Description /Display	Setting Range	Factory Setting	Property	Command address
P9-00	Motor overload protection	0: Disabled 1: Enabled	1	☆	63744
P9-01	Motor overload protection gain	0.20 to 10.00	1.00	☆	63745
P9-02	Motor overload pre-warning coefficient	50% to 100%	80%	☆	63746
P9-03	Overvoltage protection gain	0 to 100	30	☆	63747
P9-04	Overvoltage protection voltage	200.0 to 2000.0V 220V: 380V 380V: 760V	Model dependent	☆	63748
P9-05	Overcurrent protection gain	0 to 100	20	☆	63749
P9-06	Overcurrent protection current	100% to 200%	150%	☆	63750
P9-07	Detection of short-circuit to ground upon power-on	0: Disabled 1: Enabled	1	☆	63751
P9-08	Braking unit applied voltage	200.0V to 2000.0V	220V: 360V 380V: 700V	☆	63752

Code	Description /Display	Setting Range	Factory Setting	Property	Command address
P9-09	Auto reset times	0 to 20	0	☆	63753
P9-10	Selection of DO action during auto reset	0: Not act 1: Act	0	☆	63754
P9-11	Delay of auto reset	0.1 to 100.0s	1.0s	☆	63755
P9-12	Input phase loss/pre-charge relay protection	0: Disabled 1: Enabled	0	☆	63756
P9-13	Output phase loss protection	0: Disabled 1: Enabled	1	☆	63757
P9-14	1st fault type	0 to 51	-	•	63758
P9-15	2nd fault type		-	•	63759
P9-16	3rd (latest) fault type		-	•	63760
P9-17	Frequency upon 3rd fault	-	-	•	63761

Code	Description /Display	Setting Range	Factory Setting	Property	Command address
P9-18	Current upon 3rd fault	-	-	•	63762
P9-19	Bus voltage upon 3rd fault	-	-	•	63763
P9-20	DI state upon 3rd fault	-	-	•	63764
P9-21	DO state upon 3rd fault	-	-	•	63765
P9-22	AC drive state upon 3rd fault	-	-	•	63766
P9-23	Power-on time upon 3rd fault	-	-	•	63767
P9-24	Running time upon 3rd fault	-	-	•	63768
P9-27	Frequency upon 2rd fault	-	-	•	63771
P9-28	Current upon 2rd fault	-	-	•	63772
P9-29	Bus voltage upon 2rd fault	-	-	•	63773
P9-30	DI state upon 2rd fault	-	-	•	63774
P9-31	DO state upon 2rd fault	-	-	•	63775
P9-32	AC drive state upon 2rd fault	-	-	•	63776
P9-33	Power-on time upon 2rd fault	-	-	•	63777
P9-34	Running time upon 2rd fault	-	-	•	63778
P9-37	Frequency upon 1st fault	-	-	•	63781
P9-38	Current upon 1st fault	-	-	•	63782
P9-39	Bus voltage upon 1st fault	-	-	•	63783
P9-40	DI state upon 1st fault	-	-	•	63784
P9-41	DO state upon 1st fault	-	-	•	63785

Code	Description /Display	Setting Range	Factory Setting	Property	Command address
P9-42	AC drive state upon 1st fault	-	-	•	63786
P9-43	Power-on time upon 1st fault	-	-	•	63787
P9-44	Running time upon 1st fault	-	-	•	63788
P9-47	Running time upon 1st fault	Units: Motor overload (Err11) 0: Coast to stop 1: Stop according to the stop mode 2: Continue to run Tens: Input phase loss (Err12) Hundreds position: Output phase loss (Err13) Thousands: External fault (Err15) Ten thousands: Communication fault (Err16)	0	☆	63791
P9-54	Frequency selection for continuing to run upon fault	0: Current running frequency 1: Frequency reference 2: Frequency upper limit 3: Frequency lower limit 4: Backup frequency upon abnormality	0	☆	63798

Code	Description /Display	Setting Range	Factory Setting	Property	Command address
P9-55	Backup frequency upon fault	0.0% to 100.0% (100.0% corresponding max. frequency P0-10)	100.0%	☆	63799
P9-59	Power dip ride-through function selection	0: Disabled 1: Bus voltage constant control 2: Decelerate to stop	0	☆	63803
P9-60	Threshold of power dip ride-through function disabled	P9-62 to 100.0%	100.0%	☆	63804
P9-61	Judging time of bus voltage recovering from power dip	0.00 to 100.00s	0.50s	☆	63805
P9-62	Threshold of power dip ride-through function enabled	60.0% to 100.0%	80%	☆	63806

Code	Description /Display	Setting Range	Factory Setting	Property	Command address
P9-63	Load lost protection	0: Disabled 1: Enabled	0	☆	63807
P9-64	Load lost detection level	0.0 to 100.0%	10.0%	☆	63808
P9-65	Load lost detection time	0.0 to 60.0s	1.0s	☆	63809

Group PA: PID Function

Code	Description /Display	Setting Range	Factory Setting	Property	Command address
PA-00	PID reference setting channel	0: Set by PA-01 1: AI1 2: AI2 3: Potentiometer 4: Pulse reference (HDI) 5: Serial comms. 6: Multi-reference	0	☆	64000
PA-01	PID digital setting	0.0 to 100.0%	50.0%	☆	64001
PA-02	PID feedback setting channel	0: AI1 1: AI2 2: Potentiometer 3: AI1 - AI2 4: Pulse reference (HDI) 5: Serial comms. 6: AI1 + AI2 7: Max. (AI1 , AI2) 8: Min. (AI1 , AI2)	0	☆	64002
PA-03	PID operation direction	0: Forward 1: Reverse	0	☆	64003
PA-04	PID reference and feedback range	0 to 65535	1000	☆	64004
PA-05	Proportional gain Kp1	0.0 to 100.0	20.0	☆	64005
PA-06	Integral time Ti1	0.01 to 10.00s	2.00s	☆	64006

Code	Description /Display	Setting Range	Factory Setting	Property	Command address
PA-07	Differential time Td1	0.000 to 10.000s	0.000s	☆	64007
PA-08	PID output limit in reverse direction	0.00Hz to max, frequency	2.00Hz	☆	64008
PA-09	PID error limit	0.0 to 100.0%	0.0%	☆	64009
PA-10	PID differential limit	0.00 to 100.00%	0.10%	☆	64010
PA-11	PID reference change time	0.00 to 650.00s	0.00s	☆	64011
PA-12	PID feedback filter time	0.00 to 60.00s	0.00s	☆	64012
PA-13	PID output filter time	0.00 to 60.00s	0.00s	☆	64013
PA-15	Proportional gain Kp2	0.0 to 100.0	20.0	☆	64015
PA-16	Proportional gain Kp2	0.01 to 10.00s	2.00s	☆	64016
PA-17	Proportional gain Kp2	0.000 to 10.000s	0.000s	☆	64017

Code	Description /Display	Setting Range	Factory Setting	Property	Command address
PA-18	PID parameter switchover condition	0: No switchover 1: Switchover via DI 2: Auto switchover based on PID error 3: Auto switchover based on running frequency	0	☆	64018
PA-19	PID error 1 for auto switchover	0.0% to PA-20	20.0%	☆	64019
PA-20	PID error 2 for auto switchover	PA-19 to 100.0%	80.0%	☆	64020
PA-21	PID initial value	0.0 to 100.0%	0.0%	☆	64021
PA-22	PID initial value active time	0.00 to 650.00s	0.00s	☆	64022
PA-23	Two positive output deviations maximum	0.00 to 100.00%	1.00%	☆	64023
PA-24	Two output deviation reverse maximum	0.00 to 100.00%	1.00%	☆	64024

Code	Description /Display	Setting Range	Factor y Setting	Property	Command address
PA-25	PID integral property	Units position: Integral separation 0: Disabled 1: Enabled Tens position: Whether to stop integral operation when the PID output reaches the limit 0: Continue integral	00	☆	64025
PA-26	Detection level of PID feedback loss	0.0%: No detection 0.1% to 100.0%	0.0%	☆	64026
PA-27	Detection time of PID feedback loss	0.0 to 20.0s	0.0s	☆	64027
PA-28	Selection of PID operation at stop	0: Disabled 1: Enabled	1	☆	64028

Group Pb: Wobble Function, Fixed Length and Count

Code	Description /Display	Setting Range	Factory Setting	Property	Command address
Pb-00	Wobble setting mode	0: Relative to the frequency reference 1: Relative to the max. frequency	0	☆	64256
Pb-01	Wobble amplitude	0.0 to 100.0%	0.0%	☆	64257
Pb-02	Wobble step	0.0 to 50.0%	0.0%	☆	64258
Pb-03	Wobble cycle	0.1 to 3000.0s	10.0s	☆	64259
Pb-04	Triangular wave rising time coefficient	0.1 to 100.0%	50.0%	☆	64260
Pb-05	Set length	0 to 65535m	1000m	☆	64261
Pb-06	Actual length	0 to 65535m	0m	☆	64262
Pb-07	Number of pulses per meter	0.1 to 6553.5	100.0	☆	64263
Pb-08	Set count value	1 to 65535	1000	☆	64264
Pb-09	Designated count value	1 to 65535	1000	☆	64265

Group PC: Multi-Reference and Simple PLC Function

Code	Description /Display	Setting Range	Factory Setting	Property	Command address
PC-00	Reference 0	-100.0% to 100.0%	0.0%	☆	64512
PC-01	Reference 1	-100.0%to100.0%	0.0%	☆	64513
PC-02	Reference 2	-100.0% -100.0%	0.0%	☆	64514
PC-03	Reference 3	-100.0%to100.0%	0.0%	☆	64515
PC-04	Reference 4	-100.0%to100.0%	0.0%	☆	64516
PC-05	Reference 5	-100.0%to100.0%	0.0%	☆	64517
PC-06	Reference 6	-100.0%to100.0%	0.0%	☆	64518
PC-07	Reference 7	-100.0%to100.0%	0.0%	☆	64519
PC-16	Simple PLC running mode	0: Stop after running one cycle 1: Keep final values after running one cycle 2: Repeat after running one cycle	0	☆	64528

Code	Description /Display	Setting Range	Factory Setting	Property	Command address
PC-17	Simple PLC retentive selection	0: Not retentive 1: Retentive Unit position: Retentive at power down Tens position: Retentive at stop	00	☆	64529
PC-18	Running time of simple PLC reference 0	0.0s (h) to 6553.5s (h)	0.0s(h)	☆	64530
PC-19	Acceleration/deceleration time of simple PLC reference 0	0 to 3	0	☆	64531
PC-20	Running time of simple PLC reference 1	0.0s (h) to 6553.5s (h)	0.0s(h)	☆	64532
PC-21	Acceleration/deceleration time of simple PLC reference 1	0 to 3	0	☆	64533
PC-22	Running time of simple PLC reference 2	0.0s (h) to 6553.5s (h)	0.0s(h)	☆	64534
PC-23	Acceleration/deceleration time of simple PLC reference 2	0 to 3	0	☆	64535
PC-24	Running time of simple PLC reference 3	0.0s (h) to 6553.5s (h)	0.0s(h)	☆	64536

Code	Description /Display	Setting Range	Factory Setting	Property	Command address
PC-25	Acceleration/deceleration time of simple PLC reference 3	0 to 3	0	☆	64537
PC-26	Running time of simple PLC reference 4	0.0s (h) to 6553.5s (h)	0.0s(h)	☆	64538
PC-27	Acceleration/deceleration time of simple PLC reference 4	0 to 3	0	☆	64539
PC-28	Running time of simple PLC reference 5	0.0s (h) to 6553.5s (h)	0.0s(h)	☆	64540
PC-29	Acceleration/deceleration time of simple PLC reference 5	0 to 3	0	☆	64541
PC-30	Running time of simple PLC reference 6	0.0s (h) to 6553.5s (h)	0.0s(h)	☆	64542
PC-31	Acceleration/deceleration time of simple PLC reference 6	0 to 3	0	☆	64543
PC-32	Running time of simple PLC reference 7	0.0s (h) to 6553.5s (h)	0.0s(h)	☆	64544

Code	Description /Display	Setting Range	Factory Setting	Property	Command address
PC-33	Acceleration/deceleration time of simple PLC reference 7	0 to 3	0	☆	64545
PC-50	Time unit of simple PLC running	0: s (second) 1: h (hour)	0	☆	64562
PC-51	Reference 0 source	0: Set by PC-00 1: AI1 2: AI2 3: Potentiometer 4: Pulse reference HDI 5: PID 6: Set by preset frequency (P0-08), modified via terminal UP/DOWN	0	☆	64563

Group Pd: Communication

Code	Description /Display	Setting Range		Factory Setting	Property	Command address
Pd-00	Baud rate	0: 300 bps 1: 600 bps 2: 1200 bps 3: 2400 bps 4: 4800 bps	5: 9600 bps 6: 19200 bps 7: 38400 bps 8: 57600 bps 9: 115200 bps	5	☆	64768
Pd-01	Data format symbol	0: No check <8,N,2> 1: Even parity check <8,E,1> 2: Odd parity check <8,O,1> 3: No check, data format <8,N,1>		3	☆	64769
Pd-02	Local address	1 to 249 0: Broadcast address		1	☆	64770
Pd-03	Response delay	0 to 20 ms		2	☆	64771
Pd-04	Communication timeout	0.0: invalid 0.1 to 60.0s		0.0s	☆	64772
Pd-05	Modbus protocol selection data frame	1: Standard Modbus protocol		1	☆	64773
Pd-06	Current resolution read by communication	0: 0.01 A 1: 0.1 A		0	☆	64774

Pd-07	Reserved	-	0	☆	64775
-------	----------	---	---	---	-------

PP group-Code management

Code	Description /Display	Setting Range	Factory Setting	Property	Command address
PP-00	User password	0 to 65535	00000	☆	7936
PP-01	Parameter initialization	0: No operation 1: Restore factory parameters except motor parameters 2: Clear records 3: Restore factory parameters include motor parameters	000	★	7937
PP-02	Parameter display property	Units: Group U Tens: Group A Hundreds: Group b 0: Disabled 1: Enabled	111	★	7938
PP-04	Selection of parameter modification	0: Disabled 1: Enabled	0	☆	7940

Group A5: Control Optimization

Code	Description /Display	Setting Range	Factory Setting	Property	Command address
A5-00	DPWM switchover frequency upper limit	0.00 to 15.00 Hz	12.00Hz	☆	42240
A5-01	PWM modulation pattern	0: Asynchronous modulation 1: Synchronous modulation	0	☆	42241
A5-02	Dead zone compensation mode selection	0: Disabled 1: Compensation mode 1 2: Compensation mode 2	1	☆	42242
A5-03	Random PWM depth	0: Random PWM invalid 1 to 10	0	☆	42243
A5-04	Overcurrent fast prevention	0: Disabled 1: Enabled	1	☆	42244
A5-05	Current test compensation	0 to 100	5	☆	42245
A5-06	Under voltage threshold	100.0 to 2000V	Model dependent	☆	42246
A5-07	SVC optimization mode selection	0: Disabled 1: Optimization mode 1 2: Optimization mode 2	1	☆	42247
A5-08	Dead zone time adjustment	100 to 200%	150%	☆	42248

A5-09	Overvoltage threshold	200.0 to 2500.0V	Model dependent	★	42249
-------	-----------------------	------------------	-----------------	---	-------

Group U0: Monitoring Parameters

Code	Description /Display	Setting Range	Factory Setting	Property	Command address
U0-00	Running frequency (Hz)	-	0.01Hz		28672
U0-01	Frequency reference (Hz)	-	0.01Hz		28673
U0-02	Bus voltage (V)	-	0.1V		28674
U0-03	Output voltage (V)	-	IV		28675
U0-04	Output current (A)	-	0.01A		28676
U0-05	Output power(kW)	-	0.1kW		28677
U0-06	Output torque (%)	-	0.1%		28678
U0-07	X state	-	1		28679
U0-08	Y state	-	1		28680
U0-09	All voltage (V)	-	0.01V		28681
U0-10	AI2 voltage (V)	-	0.01V		28682
U0-11	Potentiometer voltage (V)		0.01V		28683
U0-12	Count value		1		28684

Code	Description /Display	Setting Range	Factory Setting	Property	Command address
U0-13	Length value		1		28685
U0-14	Load speed display		1		28686
U0-15	PID reference		1		28687
U0-16	RID feedback		1		28688
U0-17	PLC stage		1		28689
U0-18	HDI pulse reference (kHz)	-	0.01kHz		28690
U0-19	Feedback speed (0.1 Hz)	-	0.1Hz		28691
U0-20	Remaining running time	-	0.1 Min		28692
U0-21	AI1 voltage before correction	-	0.001V		28693
U0-22	AI2 voltage before correction	-	0.001V		28694
U0-23	Potentiometer voltage before correction	-	0.001V		28695
U0-24	Motor speed	-	1m/Min		28696
U0-25	Accumulative power-on time	-	1Min		28697
U0-26	Accumulative running time	-	0.1 Min		28698

Code	Description /Display	Setting Range	Factory Setting	Property	Command address
U0-27	HDI pulse reference	-	1Hz		28699
U0-28	Communication reference	-	0.01%		28700
U0-30	Main frequency reference	-	0.01Hz		28702
U0-31	Auxiliary frequency reference	-	0.01Hz		28703
U0-32	Viewing any register address value	-	1		28704
U0-35	Target torque (%)	-	0.1%		28707
U0-37	Power factor angle	-	0.1°		28709
U0-39	Reserve	-	IV		28711
U0-41	X state display	-	1		28713
U0-42	Y state display	-	1		28714
U0-43	X set for function state display 1	-	1		28715
U0-44	X set for function state display 2	-	1		28716
U0-45	Fault information	-	1		28717

Code	Description /Display	Setting Range	Factory Setting	Property	Command address
U0-59	Frequency Reference	-	0.01%		28731
U0-60	Running frequency	-	0.01%		28732
U0-61	AC drive state	-	1		28733
U0-62	Current fault code	-	1		28734
U0-65	Torque upper limit	-	0.1%		28737

Chapters Faults and Diagnostics

5.1 Faults and Diagnostics

When a fault occurs during running, the AC drive stops output immediately, and the fault code is displayed on the inverter display panel, and contact of the fault relay acts. The operation panel displays the fault code. Find and remove cause of the fault. Then follow steps

Below to reset the fault.

Err22 is the hardware overcurrent or overvoltage signal.

Fault name	Fault code	Cause	Possible Solution
Inverter unit protection	Err01	<ol style="list-style-type: none">1. Inverter output loop short circuit2. Two long wiring between motor and inverter.3. Module overheating4. Inverter internal wiring loose5. Main control board anomalies6. Drive board anomalies7. Inverter module anomalies	<ol style="list-style-type: none">1. Eliminate external faults2. Add reactor or output filter3. Check air duct, fan and eliminate existing problems.4. Insert all connecting wires5. For technical support

Fault name	Fault code	Cause	Possible Solution
Overcurrent during acceleration	Err02	<ol style="list-style-type: none"> 1. Acceleration time too short 2. Improper manual torque boost or V/F curve 3. Low voltage 4. Inverter output loop grounding or short circuit 5. Vector control mode without parameter identification 6. Start the rotating motor 7. Sudden load add in acceleration process 8. Small type selection of inverter. 	<ol style="list-style-type: none"> 1. Increase acceleration time 2. Adjust manual torque boost or V/F curve 3. Adjust voltage to normal range 4. Eliminate external faults 5. Parameter identification 6. Select speed tracking start or restart after motor stop 7. Cancel sudden added load 8. Choose inverter of greater power level
Overcurrent during deceleration	Err03	<ol style="list-style-type: none"> 1. Inverter output loop grounding or short circuit 2. Vector control mode without parameter identification 3. Deceleration time too short 4. Low voltage 5. Sudden load add in deceleration process 6. No braking unit and braking resistor installed 	<ol style="list-style-type: none"> 1. Eliminate external faults 2. Parameter identification 3. Increase deceleration time 4. Adjust voltage to normal range 5. Cancel sudden added load 6. Install braking unit and braking resistor

Fault name	Fault code	Cause	Possible Solution
Overcurrent at constant speed	Err04	<ol style="list-style-type: none"> 1. Inverter output loop grounding or short circuit 2. Vector control mode without parameter identification 3. Low voltage 4. Sudden load add in deceleration process 5. Small type selection of inverter 	<ol style="list-style-type: none"> 1. Eliminate external faults 2. Parameter identification 3. Adjust voltage to normal range 4. Cancel sudden added load 5. Choose inverter of greater power level
Overvoltage during acceleration	Err05	<ol style="list-style-type: none"> 1. No braking unit and braking resistor installed 2. High input voltage 3. External force drive motor operation during acceleration process 4. Acceleration time too short 	<ol style="list-style-type: none"> 1. Install braking unit and braking resistor 2. Adjust voltage to normal range 3. Cancel external force or install braking resistor 4. Increase acceleration time
Overvoltage during deceleration	Err06	<ol style="list-style-type: none"> 1. High input voltage 2. External force drive motor operation during deceleration process 3. Deceleration time too short 4. No braking unit and braking resistor installed 	<ol style="list-style-type: none"> 1. Adjust voltage to normal range 2. Cancel external force or install braking resistor 3. Increase deceleration time 4. Install braking unit and braking resistor

Fault name	Fault code	Cause	Possible Solution
Overvoltage at constant speed	Err07	<ol style="list-style-type: none"> 1. External force drive motor operation 2. High input voltage 	<ol style="list-style-type: none"> 1. Cancel external force or install braking resistor 2. Adjust voltage to normal range
Control power supply fault	Err08	<ol style="list-style-type: none"> 1. Input voltage is not within the specified range 	<ol style="list-style-type: none"> 1. Input voltage is not within the specified range
Under voltage fault	Err09	<ol style="list-style-type: none"> 1. Instantaneous power-off 2. Input voltage is not within the specified range 3. Bus voltage anomalies 4. Rectifier and buffer resistance anomalies 5. Drive board anomalies 6. Control board anomalies 	<ol style="list-style-type: none"> 1. Reset fault 2. Adjust voltage to normal range 3. For technical support
AC drive overload	Err10	<ol style="list-style-type: none"> 1. Small type selection of inverter. 2. Overload or motor stall 	<ol style="list-style-type: none"> 1. Choose inverter of greater power level 2. Reduce the load and check the motor and mechanical condition
Motor overload	Err11	<ol style="list-style-type: none"> 1. Small type selection of inverter 2. Improper setup of P9-01 3. Overload or motor stall 	<ol style="list-style-type: none"> 1. Choose inverter of greater power level 2. Set P9.01 correctly 3. Reduce the load and check the motor and mechanical condition

Fault name	Fault code	Cause	Possible Solution
Input phase loss	Err12	<ol style="list-style-type: none"> 1. Drive board anomalies 2. Lightning protection board (BESP) anomalies 3. Control board anomalies 4. 3-phase input power-supply anomalies 	<ol style="list-style-type: none"> 1. Replace driver, power-supply board or contactor 2. For technical support 3. Eliminate external loop faults
Output phase loss	Err13	<ol style="list-style-type: none"> 1. Wiring between motor and inverter anomalies 2. Inverter unbalanced 3-phase output 3. Drive board anomalies 4. Module anomalies 	<ol style="list-style-type: none"> 1. Eliminate external loop faults 2. Check 3-phase winding and eliminate faults 3. For technical support
IGBT overheat	Err14	<ol style="list-style-type: none"> 1. Air duct block 2. Fan damage 3. High ambient temperature 4. IGBT thermistor damage 5. IGBT module damage 	<ol style="list-style-type: none"> 1. Clean air dust 2. Replace the fan 3. Lower the ambient temperature 4. Replace thermistor 5. Replace inverter IGBT
External fault	Err15	<ol style="list-style-type: none"> 2. External fault signal is input via virtual I/O 2. External fault signal is input via virtual I/O 	<ol style="list-style-type: none"> 1. Confirm that the mechanical condition allows restart (P8-18) and reset the operation 2. Confirm that the virtual I/O parameters in group A1 are set correctly and reset the operation

Fault name	Fault code	Cause	Possible Solution
Communication fault	Err16	<ol style="list-style-type: none"> 1. Abnormal communication cable 2. Wrongly set communication expansion card P0.28 3. Wrongly set communication parameter PD group 4. Position machine operation anomalies 	<ol style="list-style-type: none"> 1. Check the communication cable 2. Set communication expansion card type correctly 3. Set communication parameter correctly 4. Check position machine cable
Contacting fault	Err17	<ol style="list-style-type: none"> 1. Input phase lack 2. Drive board , contactor anomalies 	<ol style="list-style-type: none"> 1. Eliminate external loop faults 2. Replace driver, power-supply board or contactor
Current detection fault	Err18	<ol style="list-style-type: none"> 1. The hall is abnormal. 2. The drive board is abnormal 	<ol style="list-style-type: none"> 1. Replace the hall 2. Replace the drive board
Motor auto-tuning fault	Err19	<ol style="list-style-type: none"> 1. Parameter identification process overtime 2. Wrongly set motor parameters 	<ol style="list-style-type: none"> 1. Check wire between inverter and motor 2. Set motor parameters correctly according to the nameplate
EEPROM read-write fault	Err21	<ol style="list-style-type: none"> 1. EEPROM chip damage 	<ol style="list-style-type: none"> 1. Replace main control board
Inverter hardware fault	Err22	<ol style="list-style-type: none"> 1. Presence of overvoltage 2. Presence of overcurrent 	<ol style="list-style-type: none"> 1. Treat according to overvoltage fault 2. Treat according to overcurrent fault

Fault name	Fault code	Cause	Possible Solution
Short circuit to ground	Err23	1. Motor short circuit to ground	1. Replace cable or motor
Accumulative running time reached	Err26	1. Accumulative running time reaches the setting value	1. Clear the record through parameter initialization
User-defined fault 1	Err27	1. Input user-defined fault 1 signal through multi-function terminal X 2. Input user-defined fault 1 signal through virtual IO function	1. Reset operation
User-defined fault 2	Err28	1. Input user-defined fault 2 signal through multi-function terminal X 2. Input user-defined fault 2 signal through virtual IO function	1. Reset operation
Accumulative power-on time reached	Err29	1. Accumulative power-on time reaches the setting value	1. Clear the record through parameter initialization
Load loss	Err30	1. The output current of AC drive is smaller than P9-64 (load loss detection level)	1. Check whether load is disconnected or the setting of F9-64 and F9-65 (load lost detection time) satisfies actual running condition.
PID feedback lost during running	Err31	1. PID feedback is smaller than the setting value of PA-26 (detection level of PID feedback loss)	1. Check PID feedback or set PA-26 properly

Fault name	Fault code	Cause	Possible Solution
Pulse-by-pulse current limit fault	Err40	<ol style="list-style-type: none"> 1. Excessive load or motor stall 2. Small type selection of inverter 	<ol style="list-style-type: none"> 1. Reduce the load and check the motor and mechanical condition 2. Choose inverter of greater power level
Motor switchover fault during running	Err41	<ol style="list-style-type: none"> 1. Motor switchover fault during running 	<ol style="list-style-type: none"> 1. Perform motor switchover after the AC drive stops
Motor over temperature	Err45	<ol style="list-style-type: none"> 1. Temperature sensor wiring loose 2. Motor over temperature 	<ol style="list-style-type: none"> 1. Check sensor wiring and eliminate fault 2. Reduced carrier frequency or take other cooling measures for the motor
Initial position fault	Err51	<ol style="list-style-type: none"> 1. Excessive deviation between motor parameters and the practical value 	<ol style="list-style-type: none"> 1. Reconfirm motor parameter settings, pay attention to the rated current value

5.2 Common fault and solutions

During the inverter using process, the following faults may occur. Please conduct simple fault analysis by referring to the methods below:

S/N	Fault Phenomenon	Possible Cause	Solution
1	No display or error codes occur upon power-on	Abnormal input power supply, switch power supply fault of driven board, rectifier bridge damage, inverter buffer resistance damage, control board/keyboard fault, control board/driven board/keyboard disconnection	Check input power supply, bus voltage, re-plug 26 core cable, consult the manufacturer
2	Display [Con...] upon power-on	Poor contact between driven board and control board, device damage on control board, motor or motor cable short circuited, hall fault, grid under voltage	Re-plug 26 core cable, consult the manufacturer
3	"Error 23=Err23" alarming upon power on	The motor or the output line is short circuited to the earth the inverter is damaged.	Measure the insulation of the motor and output line with magneto-ohmmeter, consult the manufacturer

S/N	Fault Phenomenon	Possible Cause	Solution
4	The inverter displays normally upon power-on, but [] is displayed upon running and stops immediately	The fan is either damaged or blocked, peripheral controller short circuited	Replace the fan, exclude external short-circuit fault
5	Frequent fault report ERR14=Err14 (module overheating)	The carrier frequency is set too high, the fan is damaged or the air duct is blocked, inverter internal components damaged	Replace the fan, clean air duct, reduce carrier frequency(P0-15), consult manufacturer
6	Motor no rotating after inverter power-on	Motor or motor cable, wrongly set inverter parameters(motor parameter), poor contact between driven board and control board, driven board fault	Replace the motor or remove the mechanical fault, check and reset the parameters, confirm connection between inverter and motor
7	The inverter frequently reports over current fault & over voltage fault	Motor wrongly set parameters, improper acc./dec. time, load fluctuation	Reset motor parameters or motor tuning, set proper acc./dec. time, consult manufacturer
8	Display  upon power-on	The control board damaged	Replace the control board

Appendix I RS485 Communication Protocol

I-1 RS485 communication

DSI-300 series inverter as internal RS485 communication circuit. It contains the following resources:

Table 2 Jumper description

Jumper number	Description
J1	RS485 Termination resistor selection

I-2 Communication protocol

I-2-1 Protocol content

The serial communication protocol defines the information content and format of the use of the transmission in serial communication. Including: the host polling (or broadcast) format、host encoding methods. Consent including: require action of the function code, data transmission and error checking and so on. Slave machine's response is the same structure, including: action confirmation, return data and error checking. Slave error occurred when receiving information, or cannot do what the host request action, it will organize a fault messages the response back to the host computer.

Application mode:

The inverter accessing with “single main multi-slave” PC/PLC control network which equipped with RS485 bus.

Bus structure:

(1) Interface mode

RS485 hardware interface

(2) Transmission mode

Asynchronous serial, half-duplex transmission. At the same time host and slave computer can only permit one to send data while the

other can only receive data. Data in the process of serial asynchronous communication is in the message format and sent one frame by one frame.

(3) Topological mode

In single-master system, the setup range of slave address is 1 to 247. Zero refers to broadcast communication address. The address of slave must be exclusive in the network. That is one condition of one slave machine.

I-3 Protocol Description

DSI-300 series inverter communication protocol is an asynchronous serial master-slave Modbus communication protocol, only one device in the network (master) to establish protocol (known as the "query / command"). Other device (slave) can only provide data response to the host query / command, or make the appropriate action according to the host query / command. Host refers to a personal computer (PC), industrial control equipment, or programmable logic controller (PLC), etc. The slave indicates DSI-300 inverter. Host can not only communicate separately with the slave, but also broadcast messages to the lower machine. For separate access to the host query / command, the slave should return a message (called the response), and for broadcast information issued by host machine, feedback needs not to be responded to the host.

Communication data structure DSI-300 series inverter Modbus protocol communication data format is as follows: using RTU mode, messages are sent at least at interval of 3.5 bytes times pause. In a variety of bytes in the network baud rate of time, this could be most easily achieved (see below T1-T2-T3-T4 shown). The transmission of a domain is the device address.

Transmission characters are hexadecimal 0...9, A...F. Network

equipment continue to detect the network bus, including a pause interval of time. When the first field (the address field) is received, each device decodes it to determine whether sent to their own. At least 3.5 bytes times pause after the last transmitted character, a calibration of the end of the message. A new message may start after this pause.

The entire message frame must be used as a continuous stream. If the pause time frame prior to the completion of more than 1.5 byte times, the receiving device will refresh the incomplete message and assumes that the next byte will be the address field of a new message. Similarly, if a new message starts in less than 3.5 bytes times following the previous message, the receiving device will consider it a continuation of the previous message. This will set an error, as the value in the final CRC field will not be valid for the combined messages. A typical message frame is shown below.

RTU frame format:

START	3.5-character time
Slave address ADDR	Communication address: 1~247
Command code CMD	03: Read slave parameters; 06: Write slave parameters
DATA(N-1)	Function code parameter address, function code parameter number, function code parameter value, etc.
DATA(N-2)	
.....	
DATA0	
CRC CHK low order	Detection value: CRC value.
CRC CHK high order	
END	At least 3.5-character time

CMD (command instructions) and DATA (material words description)

Command code: 03H, reads N words (There are 12 characters can be read at most). For example: the inverter start address F0.02 of the slave machine address 01 continuously reads two consecutive values.

Host command

ADR	01H
CMD	03H
Start address high order	F0H
Start address low order	02H
Register number high order	00H
Register number low order	02H
<i>CRC CHK low order</i>	CRC CHK values to be calculated
<i>CRC CHK high order</i>	

Slave response**PD.05=0 :**

ADR	01H
CMD	03H
Byte number high order	00H
Byte number low order	04H
Data P002H high order	00H
Data P002H low order	00H
Data P003H high order	01H
<i>CRC CHK low order</i>	CRC CHK values to be calculated
<i>CRC CHK high order</i>	

PD.05=1 :

ADR	01H
CMD	03H
Byte number	04H

Data F002H high order	00H
Data F002H low order	00H
Data F003H high order	00H
Data F003H low order	01H
<i>CRC CHK low order</i>	CRC CHK values to be calculated
<i>CRC CHK high order</i>	

Command code: 06H write a word

For example: Write 5000(1388H) into F00AH which slave address is 02H.

Master command information

ADR	02H
CMD	06H
Data address high order	F0H
Data address low order	0AH
Data content high order	13H
Data content low order	88H
<i>CRC CHK low order</i>	CRC CHK values to be calculated
<i>CRC CHK high order</i>	

Slave response

ADR	02H
CMD	06H
Data address high order	F0H
Data address low order	0AH
Data content high order	13H
Data content low order	88H
<i>CRC CHK low order</i>	CRC CHK values to be calculated
<i>CRC CHK high order</i>	

I-4 Cyclical Redundancy Check :

Cyclical Redundancy Check—CRC mode: CRC (Cyclical Redundancy Check) is in RTU frame format, message contains an error-checking field that is based on a CRC method. The CRC field checks the contents of the entire message. The CRC field is two bytes, containing a 16-bit binary value. The CRC value is calculated by the transmitting device, which appends the CRC to the message. The receiving device recalculates a CRC during receipt of the message, and compares the calculated value to the actual value it received in the CRC field. If the two values are not equal, an error results. The CRC is started by 0xFFFF. Then a process begins of applying successive 8-bit bytes of the message to the current contents of the register. Only the eight bits of data in each character are used for generating the CRC. Start and stop bits, and the parity bit, DO not apply to the CRC.

During generation of the CRC, each eight-bit character is exclusive XOR with the register contents. Then the result is shifted in the direction of the least significant bit (LSB), with a ZERO filled into the most significant bit (MSB) position. The LSB extracted and examined. If the LSB was 1, the register then exclusive XOR with a preset, fixed value. If the LSB was 0, no exclusive XOR takes place. This process is repeated until 8 shifts have been performed. After the last (8) shift, the next eight-bit byte is exclusive XOR with the register's current value, and the process repeats for 8 more shifts as described above. The final contents of the register, after all the bytes of the message have been applied, is the CRC value.

When CRC appended to the message, the low byte is appended first, and then the high byte.

CRC calculation program:

```
Unsigned int cal_crc16 (unsigned char *data, unsigned int length)
```

```
{
unsigned int i,crc_result=0xffff;
while(length--)
{
crc_result^=*data++;
for(i=0;i<8;i++)
{
if(crc_result&0x01)
crc_result=(crc_result>>1)^0xa001;
else
crc_result=crc_result>>1;
}
}
crc_result=((crc_result&0xff)<<8)|(crc_result>>8);
return(crc_result);
```

I-5 Communication parameter address

The chapter is about communication contents, it's used to control the inverter operation, the status of the inverter and related parameter setup. Read and write function code parameters (Some function codes are not able to be changed, only for the manufacturer use.). The mark rules of function code parameters address:

The group number and mark of function codes are parameter address for indication rules.

High byte: F0~FF (P group), A0~AF (A group), 70~F (U group) Low byte: 00~FF

For example: P3.12, the address indicates F30C

Caution:

Group PF: Parameters could not be read or be modified.

Group U: Parameters could be read but not be modified.

Some parameters can not be changed during operation, some parameters regardless of the kind of state the inverter in, the parameters cannot be changed. Change the function code parameters, pay attention to the scope of the parameters, units, and relative instructions.

Besides, if EEPROM is frequently stored, it will reduce the service life of EEPROM. In some communication mode, function code needn't to be stored as long as changing the RAM value.

Group P: to achieve this function, change high order F of the function code address into 0.

Group A: to achieve this function, change high order A of the function code address to be 4.

Corresponding function code address are indicated below:

High byte: 00~0F (P group), 40~4F (A group)Low byte: 00~FF

For example:

Function code P3.12 cannot be stored into EEPROM, address indicates to be 030C,function code A0-05 cannot be stored in EEPROM, address indicates to be 4005; This address can only act writing RAM, it cannot act reading, when act reading, it is invalid address. For all parameters, command code 07H can be used to achieve this function.
Stop/running parameter:

Parameter address	Parameter description
1000	* Communication setup value(-
1001	Running frequency
1002	Bus voltage
1003	Output voltage
1004	Output current
1005	Output power
1006	Output torque
1007	Running speed
1008	DI input status
1009	DO output status
100A	AI1voltage
100B	AI2 voltage
100C	AI3 voltage
100D	Counting value input

100E	Length value input
100F	Load speed
1010	PID setup
1011	PID feedback
1012	PLC process
1013	PULSE input pulse frequency, unit
1014	Feedback speed, unit 0.1Hz
1015	Rest running time
1016	AI1 voltage before correction
1017	AI2 voltage before correction
1018	AI3 voltage before correction
1019	Line speed
101A	Current power on time
101B	Current running time
101C	PULSE input pulse frequency, unit 1Hz
101D	Communication setup value
101E	Actual feedback speed
101F	Main frequency X display
1020	Auxiliary frequency Y display

Caution:

The communication setup value is percentage of the relative value, 10000 corresponds to 100.00%, -10000 corresponds to -100.00%. For data of dimensional

frequency, the percentage value is the percentage of the maximum frequency. For data of dimensional torque, the percentage is P2.10, A2.48, A3.48, A4.48 (Torque upper digital setup, corresponding to the first, second, third, fourth motor).

Control command input to the inverter (write-only)

Command word address	Command function
2000	0001: Forward operation
	0002: Reserved operation
	0003: Forward jog
	0004: Reserved jog
	0005: Free stop
	0006: Speed-Down stop
	0007: Fault reset

Read inverter status: (read-only)

Status word address	Status word function
3000	0001: Forward operation
	0002: Reserved operation
	0003: Stop

Parameters lock password check: (if the return is the 8888H, it indicates the password checksum pass)

Password address	Contents of input password
1F00	*****

Digital output terminal control: (write-only)

Command address	Command content
2001	BIT0: DO1 Output control BIT1: DO2 Output control BIT2 RELAY1 Output control BIT3: RELAY2 Output control BIT4: FMR Output control BIT5: VY1 BIT6: VY2 BIT7: VY3 BIT8: VY4 BIT9: VY5

Analog output AO1 control: (write-only)

Command address	Command content
2002	0~7FFF indicates 0%~100%

Analog output AO2control: (write-only)

Command address	Command content
2003	0~7FFFIndicates 0%~100%

(PULSE) output control : (write-only)

Command address	Command content
2004	0~7FFFIndicates 0%~100%

Inverter fault description:

Inverter fault address	Inverter fault information
8000	0000: No fault

	0001: Reserved
	0002: Speed-up over current
	0003: Speed-down over current
	0004: Constant speed over current
	0005: Speed-up over voltage
	0006: Speed-DOWN over voltage
	0007: Constant speed over voltage
	0008: Buffer resistance overload fault
	0009: Under-voltage fault
	000A: Inverter overload
	000B: Motor overload
	000C: Input phase lost
	000D: Output phase lost
	000E: Module overheating
	000F: External fault
	0010: Communication fault
	0011: Contactor fault
	0012: Current detection fault
	0013: Motor tuning fault
	0014: Encoder/PG card fault
	0015: Parameter read and write fault
	0016: Inverter hardware fault
	0017: Motor earthing short-circuit fault
	0018: Reserved
	0019: Reserved
	001A: Running time arrive fault
	001B: User defined fault 1
	001C: User defined fault 2
	001D: Power on time arrive fault
	001E: Load off
	001F: PID feedback lost during operation
	0028: Fast current limit timeout fault
	0029: Motor shifting fault during operation
	002A: Excessive speed deviation

	002B: Motor over speed 002D: Motor over-temperature 005A: Encoder line number setup fault 005B: Encoder not connected 005C: Initial position error 005E: Speed feedback fault
--	--

Communication fault information describing data (fault code) :

Communication fault address	Fault function description
8001	0000: No fault 0001: Password error 0002: Command code error 0003: CRC check error 0004: Invalid address 0005: Invalid parameter 0006: Parameter change invalid 0007: The system is locked 0008: Operating EEPROM

Pd group communication parameters description

	Baud rate	factory default value	6005
Pd.00	Setup range	1 bit: MODUBS baud rate 0: 300BPS 1: 600BPS 2: 1200BPS 3: 2400BPS 4: 4800BPS 5: 9600BPS 6: 19200BPS 7: 38400BPS 8: 57600BPS 9: 115200BPS	

This parameter is used to set the data transfer rate between the host computer and the inverter. Caution : The baud rate of the position machine and the inverter must be consistent.

Or, communication is impossible. The higher the baud rate is, the faster the communication is.

Pd.01	Data format	Factory default value	0
	Setup range	0: No check: data format <8,N,2> 1: Even parity check: data format <8,E,1> 2: Odd parity check: data format <8,O,1> 3: No check: data format <8-N-1>	

The data format of the position machine and the inverter setup must be consistent, otherwise communication is impossible.

Pd.02	Local address	Factory default value	1
	Setup range	1~247, 0 is broadcast address.	

When the local address is set to 0, that is the broadcast address, achieve position machine's broadcast function. The local address is unique (except for the broadcast address), which is the basis for the position machine and the inverter point to point communication.

Pd.03	Response delay	Factory default value	2ms
	Setup range	0~20ms	

Response delay: it refers to the interval time from the inverter finishes receiving data to sending data to the position machine. If the response

delay is less than the system processing time, then the response based on the time delay of the system processing time. If the response delay is more than the system processing time, after the system process the data, it should be delayed to wait until the response delay time is up, then sending data to host machine.

Pd.04	Communication Overtime	Factory default value	0.0 s
	Setup range	0.0 s (Invalid) 0.1~60.0s	

When the function set to 0.0s, the communication overtime parameter is invalid.

When the function code is set to valid value, if the interval time between one communication with the next communication exceeded the communications overtime, the system will report communication fault error (fault serial 16= E.CoF1) . Under normal circumstances, it will be set to invalid value. If the system of continuous communication, setting parameters, you can monitor the communication status.

Pd.05	Communication protocol selection	Factory default value	0
	Setup range	0: Nonstandard Modbus protocol 1: Standard Modbus protocol	

Pd.05=1: Select Standard Modbus protocol.

Pd.05=0: Reading command, the slave returns the number of bytes which has one more byte than the standard Modbus protocol, for specific please refer to the protocol, the part of the "5 communication data structure".

Pd.06	Communication read the current resolution	Factory default value	0
	Setup range	0: 0.01A 1: 0.1A	

To determine when the communication reads the output current, what the output current value unit i

Warranty Agreement

1. The warranty period of the product is 18 months (refer to the barcode on the equipment). During the warranty period, if the product is failure or damaged under the condition of normal use by following the instructions, DSI-300 Electric will be responsible for free maintenance.
2. Within the warranty period, maintenance will be charged for the damages caused by the following reasons:
 - a. Improper use or repair/modification without prior permission
 - b. Fire, flood, abnormal voltage, other disasters and secondary disaster
 - c. Hardware damage caused by dropping or transportation after procurement
 - d. Improper operation
 - e. Trouble out of the equipment (for example, external device)
3. If there is any failure or damage to the product, please correctly fill out the Product Warranty Card in detail.
4. The maintenance fee is charged according to the latest Maintenance Price List of DSI-300 Electric.
5. The Product Warranty Card is not re-issued. Please keep the card and present it to the maintenance personnel when asking for maintenance.
6. If there is any problem during the service, contact DSI-300 Electric's agent or DSI-300 Electric directly.
7. This agreement shall be interpreted by DSI-300 Electric Limited.

